



Baureihe 50 - Type 50

2/2 - Wege Magnetventil

2/2 - Way solenoid valve

Standardtype

Ventil in Ruhestellung geschlossen-(NC). Bei erregtem Magnet baut sich die Druckdifferenz von der Sekundärseite des Kolbens über die Servobohrung ab. Die wirksame Druckdifferenz hebt den Kolben vom Ventilsitz ab. Der angegebene Mindestdruck muß als Druckdifferenz immer vorhanden sein.

Standrad type

Valve non-energised closed by spring power - NC. When energised, the pressure decomposes on the secondary side of the piston. Then the pressure differential (Δp) lifts the piston from the seat (orifice). A pressure differential (Δp) is necessary for accurate operation.



Steuerungsart: Type of control:	servogesteuert pilot operated	Dichtung: Seal:	NBR NBR
Konstruktion: Construction:	Kolbensitzventil Piston design	Einbaulage: Installation:	beliebig in any position
Anschluß: Connection:	G1/4-G2, DIN ISO 228 G1/4-G2, DIN ISO 228	Anschlußspannung: Supply voltage:	AC: 24,42,110,230V 50/60Hz DC: 24,110,205V=
Druck: Pressure:	1-40 bar (s. Tabelle) 1-40 bar (see table)	Spannungstoleranz: Voltage tolerance:	+5% / -10% +5% / -10%
Durchflußmedium: Medium:	neutrale, gasförmige u. flüssige Medien neutral, gaseous and liquid medium	Leistungsaufnahme: Power-consumption:	1012=18,5 Watt 0012=43/24 VA 1692=25 Watt 3692=25 Watt 1148=10 Watt 0148=9 VA
Viskosität: Viscosity:	22mm ² /s 22mm ² /s	Schutzart: Enclosure standard:	IP65 nach DIN 40050 IP65 according to DIN 40050
Mediumtemperatur: Medium temperature:	-10 bis +80°C -10 up to +80°C	Einschaltdauer: Operating factor:	100% ED-VDE 0580 100% ED-VDE 0580
Umgebungstemperatur: Ambient temperature:	+35°C +35°C	Kabelanschluß: Electric connection:	Gerätestecker DIN 43650 DIN 43650 - Plug
Ventilgehäuse: Body material:	../10../ = Messing / Brass ../08../ = Edelstahl 1.4581 / St. steel (AISI 316Ti)		
Metall. Innenteile: Metallic internals:	Messing und Edelstahl 1.4104 Brass and stainless steel (AISI 430F)		

G	Sitz Orifice Ømm	Kv-Wert Flow-rate m ³ /h	Standardtype Standard-type	max. Druck bei Magnettype max. pressure reagrding solenoid type Ex II 2G EEx m II T4		
				.012	.692-NO	.148
1/4	13	1,8	A5021/1001/....	1-40	1-40	1-25
3/8	13	4,0	A5022/1001/....	1-40	1-40	1-25
1/2	13	4,5	A5023/1001/....	1-40	1-40	1-25
3/4	25	11,5	A5024/1001/....	1-40	1-40	1-25
1	25	13,0	A5025/1001/....	1-40	1-40	1-25
5/4	40	29,0	B5026/1001/....	1-40	1-40	1-25
6/4	40	33,0	B5027/1001/....	1-40	1-40	1-25
2	50	49,0	B5028/1001/....	1-40	1-40	1-25
Edelstahl 1.4581 / Stainless steel (AISI 316Ti)						
1/4	13	1,8	E5021/0801/....	1-40	1-40	1-25
3/8	13	4,0	E5022/0801/....	1-40	1-40	1-25
1/2	13	4,5	E5023/0801/....	1-40	1-40	1-25
3/4	25	11,5	E5024/0801/....	1-40	1-40	1-25
1	25	13,0	E5025/0801/....	1-40	1-40	1-25
5/4	40	29,0	B5026/0801/....	1-40	1-40	1-25
6/4	40	33,0	B5027/0801/....	1-40	1-40	1-25
2	50	49,0	B5028/0801/....	1-40	1-40	1-25

Maßzeichnung Standardausführung
Dimensional drawing of standard type

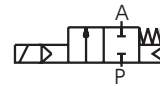
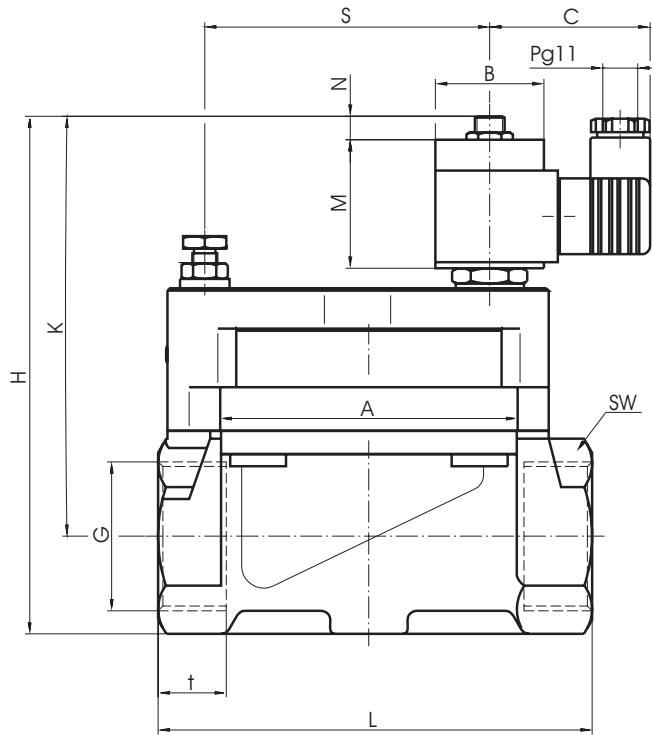

Schaltfunktion/Function:
in Ruhestellung geschlossen - NC.
Normally closed - NC.

Anschlußplan / Connection diagram

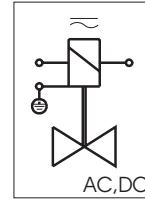

Für Wechsel- und Gleichspannung.
For AC and DC.

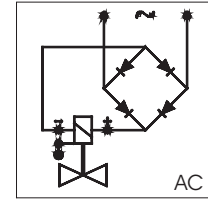

Mit vorgeschaltetem Gleichrichter für Wechselspannung.
With rectifier for AC connection

Erdung oder Schutzschaltung nach Vorschrift des zuständigen EVU.
Grounding or earthing of the protective circuit in accordance with regulations of the responsible electric supply company.

Absicherung entsprechend der Stromaufnahme vorsehen.
Appropriate protection according to the power-consumption.

Magn. Solen.	.012/ .148								.692-NO							
Type	5021	5022	5023	5024	5025	5026	5027	5028	5021	5022	5023	5024	5025	5026	5027	5028
G	1/4	3/8	1/2	3/4	1	5/4	6/4	2	1/4	3/8	1/2	3/4	1	5/4	6/4	2
A	50	50	50	70	70	96	96	112	50	50	50	70	70	96	996	112
B	35/32	35/32	35/32	35/32	35/32	35/32	35/32	35/32	35/35	35/35	35/35	35/35	35/35	35/35	35/35	35/35
C	58	58	58	58	58	58	58	58	66	66	66	66	66	66	66	66
H	130	130	130	149	149	172	172	184	145	145	145	164	164	187	187	199
K	115	115	115	125	125	140	140	145	130	130	130	140	140	155	155	155
L	67	67	67	95	95	140	140	168	67	67	67	95	95	140	140	168
M	40	40	40	40	40	40	40	40	50	50	50	50	50	50	50	50
N	10	10	10	10	10	10	10	10	10	10	10	10	10	10	10	10
Pg	11	11	11	11	11	11	11	11	11	11	11	11	11	11	11	11
SW	27	27	27	41	41	58	58	70	27	27	27	41	41	58	58	70
t	12	12	12	16	16	22	22	25	12	12	12	16	16	22	22	25
kg	1,4	1,4	1,4	2,8	2,8	3,7	3,7	5,2	1,6	1,6	1,6	3,0	3,0	3,9	3,9	5,4

Alle Angaben sind freibleibend und unverbindlich / All technical specifications are without obligation!

Weitere Ventilausführungen

Optional extras

Dichtung = FKM, EPDM, PTFE
Seal = FKM, EPDM, PTFE

Handbetätigung = HA
Manual operation = HA

Andere Durchflußmedien und Viskositäten
Varying medium and viscosity ranges

Regulierbare Schließdämpfung (ab G5/4 serienmäßig) = SR
Variable close muting (from G5/4 standard) = SR

Abweichende Temperaturen und Drücke
Varying temperature and pressure ranges

Öl- und fettfrei = OF
Free of oil and grease = OF (for oxygen applications)

Ventilgehäuse = Edelstahl 1.4581
Body material = Stainless steel (AISI 316Ti)

Buntmetallfrei = BF
Free of brass and bronze = BF

Stellungsanzeiger (Endschalter ab G3/4) = EH
Position indicator (reed contact from G3/4) = EH

Temperaturausführung bis +200°C = TH
Design for high temperature up to +200°C = TH

Ex-Schutz = Ex II 2G EEx md II cT4
Explosion proof = Ex II 2G EEx md II cT6

Grundmengeneinstellung = GM
Base of volume adjustable = GM

Temperaturausführung bis +130°C = TM
Design for high temperature up to +130°C = TM

Abgedichteter Ankerraum = AA
Sealed plunger = AA

Ex-Schutz Ex II 2G EEx m II T4 von 1-40 bar mit Magnet / .328
Explosion proof Ex II 2G EEx m II T4 from 1-40 bar with sol. / .328

Stromlos geöffnet, Kompressorlastungsventil = NP
Non energised open, compressor relief valve = NP



Stückliste - Parts list

Baureihe / Type B5021-B5025

- K1.1 Armatur / Valve body
- K2.1 Deckel / Bonnet
- *K3.2 Ventilkolben / Piston
- *K3.3 Scheibe / Disk
- *K3.7 Führungsschraube / Guide screw
- K3.13 Dämpfungsschraube / Damping screw
- K3.14 Scheibe / Disk
- *K3.16 Nutring / U-cup seal
- *K3.18 O-Ring / O-ring
- *K3.23 O-Ring / O-ring
- *K3.24 O-Ring / O-ring
- *K3.25 O-Ring / O-ring
- K3.28 6-kt. Mutter / Hexagon nut
- *K3.29 Senkschraube / Screw
- K3.31 Gewindesttiff / Grub screw
- *K3.32 Feder / Spring
- K5.1 Magnethülse / Solenoid tube
- K5.2 Magnetanker / Solenoid plunger
- K5.8 6-kt. Mutter / Hexagon nut
- K5.9 Federscheibe / Disk
- K5.10 Ankerfeder / Spring
- K6.1 Magnetspule / Solenoid
- K7.1 Stecker o. Klemmkasten / Plug or terminal box

* = Bestandteil des Ersatzteilkäppchens
(je nach Ausführung freibleibend)

* = All components of spare parts and service sets are variable in reference to different versions and executions. (These specifications are without obligation).

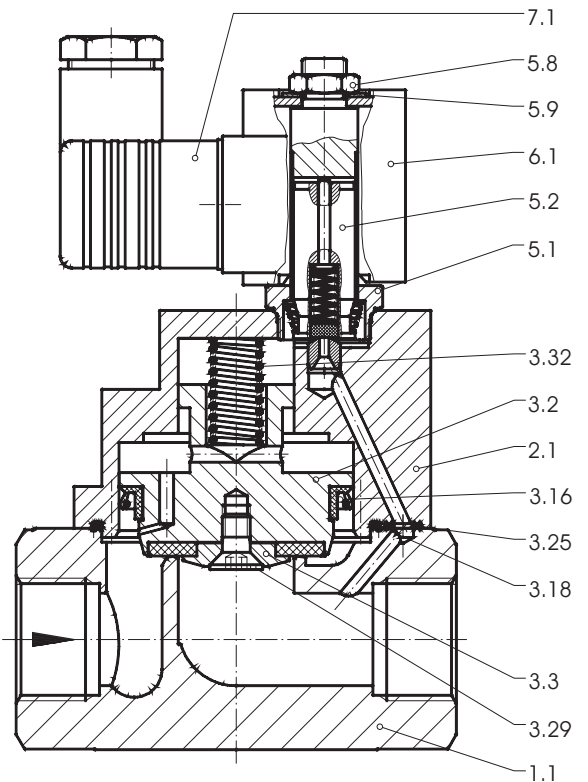

Regulierbare Schließdämpfung - SR (von G5/4-G2 serienmäßig)
variable close muting - SR (from G5/4-G2 standard)

Baureihe / Type B5026-B5028

Schraube nach rechts drehen : Ventil schließt langsamer
Screw to the right site : Valve closes slower
Schraube nach links drehen : Ventil schließt schneller
Screw to the left site : Valve closes faster

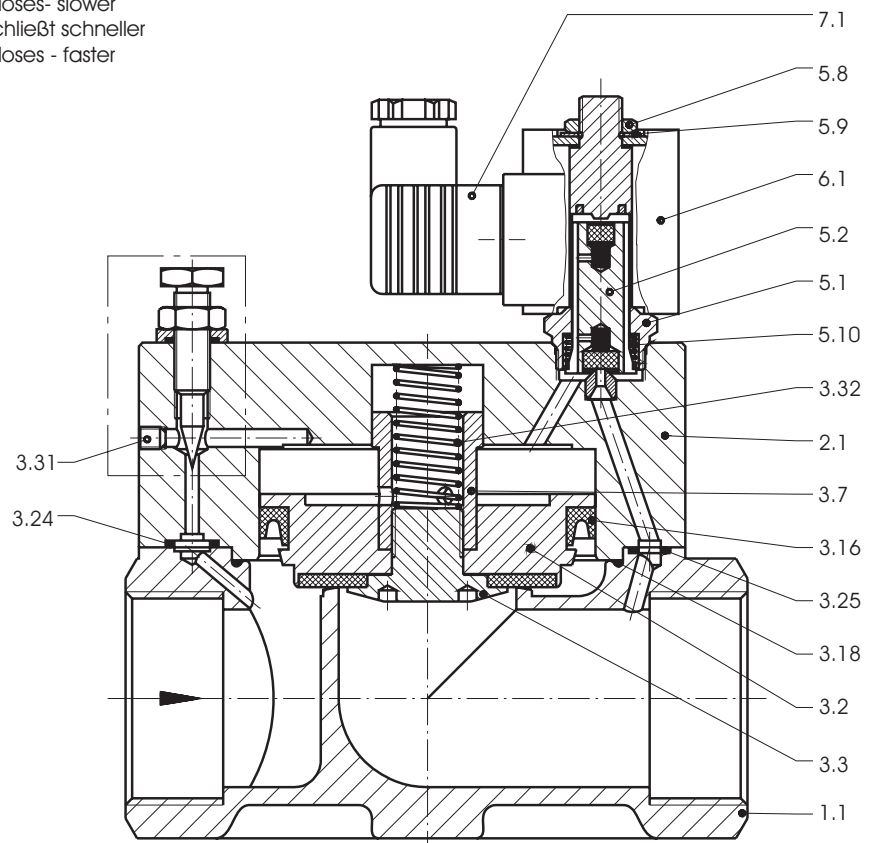
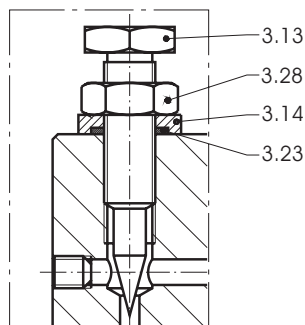

Ventiloptionen / Optional extras

Handbetätigung - HA bei Magnet .012/.148
 Manual override - HA for solenoid .012/.148

- K2.1 Deckel / Bonnet
- K3.62 Handbetätigung / Manual operation
- K3.65 O-Ring / O-ring

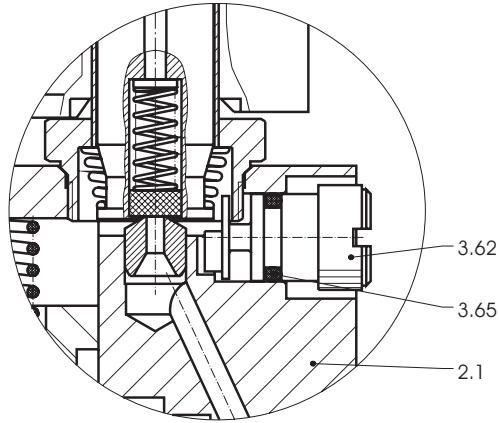

Stellungsanzeiger - EH (ab G3/4)
 Position indicator - EH (from G3/4)

- K3.75 Zwischenverschraubung / Screw joint
- K3.76 Spindel / Stem
- K3.79 O-Ring / O-ring
- K3.82 Senkschraube / Screw
- K3.83 Permanentmagnet / Permanent magnet
- K3.84 Klemmring / Clamp ring
- K3.85 Verschraubung / Screw joint
- K3.86 Endschalter / Position indicator

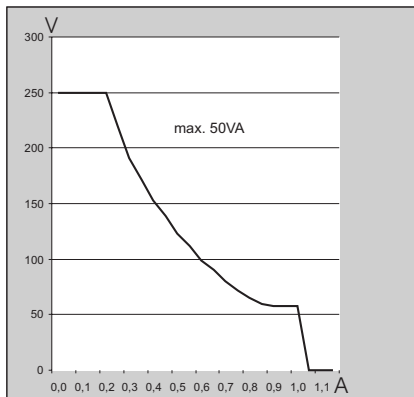
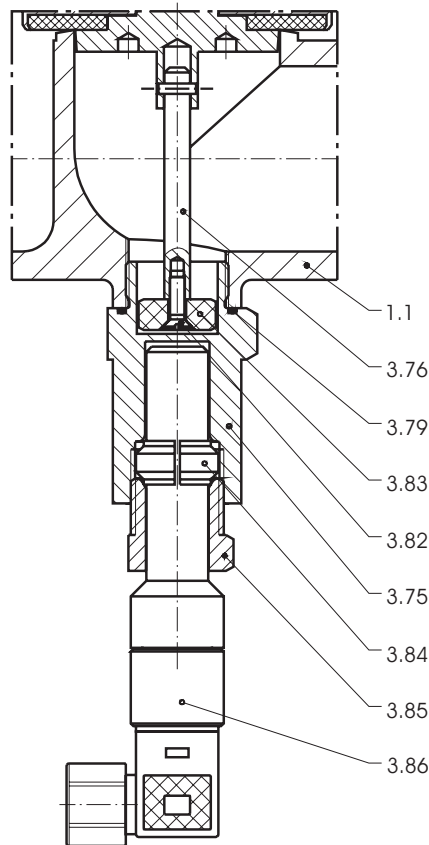

Schaltleistungsdiagramm
 Breaking capacity-graph

Anschlußplan
 Connection plan
 Endschalter / Position indicator

